



Room Guard



DATA SHEET

☎ +44 20 8895 6455
✉ info@webbinfra.com
🌐 www.webbinfra.com

Environmental Monitoring

Webb environmental monitoring products permit you to actively monitor the conditions in BTS stations, warehouses, datacenters, colleges /educational institutes, hospitals, offices, restaurants, farmsteads, factories, museums or wherever it is essential to have a climate controlled environment. Upholding a constant & steady environment where equipment or products are housed is critical for operation, protection and usage in various industries. Conditions monitoring consist of temperature, humidity, power spikes and surges, liquid leakage, SNMP traps from other devices along with smoke & airflow.

Webb environmental monitoring equipment allows network machinists to detect conditions from a secure web interface and obtain SNMP, E-mails, and text message or siren/alert warnings when environmental sensors detect a breach in the preset thresholds. These products can also make you cognizant of the potential damages from critical failures. The Web interface can demonstrate live video surveillance and environmental magnitudes, which are logged to track patterns.

T.10.335- Room Guard

Features

- Very dependable and consistent monitoring unit with digital inputs
- Environmental monitoring of any amenities, control of security breaches, temperatures, smoke, water leakages & voltages
- Compatible with all Webb sensors
- Delivers a wide-ranging environmental, access control and security monitoring solution
- Receive warnings of irregular events via email, SMS / MMS, SNMP traps
- Integrates with network management systems via SNMP v.1 and Encrypted SNMP v.3
- Uses Linux operating system for maximum solidity, reliability and flexibility
- Web GUI for PC, smartphones and tablets with free firmware upgrades and utilities
- Compatible with the entire range of multiple third-party sensors
- Embedded web server displays sensor information and live video from connected cameras

**Specifications are subject to change without notice based on technical recommendations and related product enhancements*



**Specifications are subject to change without notice based on technical recommendations and related product enhancements*

Technical Specifications

Dimensions	179x33.1x79mm
Weight	0.7 kg
Inputs	4 analog sensors, HS USB, 4 dry contacts (3P, pitch 3,5mm, type IN)
Operating characteristics	Temperature: minimum. -10° C - maximum.80° C, humidity: minimum. 5% - maximum. 95% (non-condensing)
Power input	12V DC, 0,5A
Network interface	Ethernet 10/100 Mbit/s, CAN open, 1-wire (with extension), CAN bus
Outputs	Two 12V 0,25A outputs (pitch 3,81mm, 3P)
Mounting	19" rack mountable (with extension), desktop, wall turnable mount (with extension), wall mount, 19" rack mountable
Extension protocols	CAN
Expansions (ordered separately)	1-wire board, T.10.700 / GSM modem
Power consumption	6 Watt
Status indicators	LED indication for power / network connectivity, error LED & two relay status LEDs
Components	Manufactured in E.U
Max. distance	225 m
HS code	8471 50 000
Processor	ARM926-300 MHz / 64 MB / Linux-2.6.38
Built-in sensors	Temperature sensor (1%), power supply voltage sensor (1%)
Package inclusions	Adapter 12V, Patch cable RJ-45 1m, self-adhesive rubber foot 4 pcs, short description and connection guide, warranty card, terminal plug 6 pins 3.5 mm 1pcs
Accessories (ordered separately)	T.10.102a / 19" holder (for T.10.335), T.10.112 / rotatable mounting brackets
Others	Restart button, recovery switch & chassis grounding (M4 thread)

**Specifications are subject to change without notice based on technical recommendations and related product enhancements*

Dimensions (T.10.335)

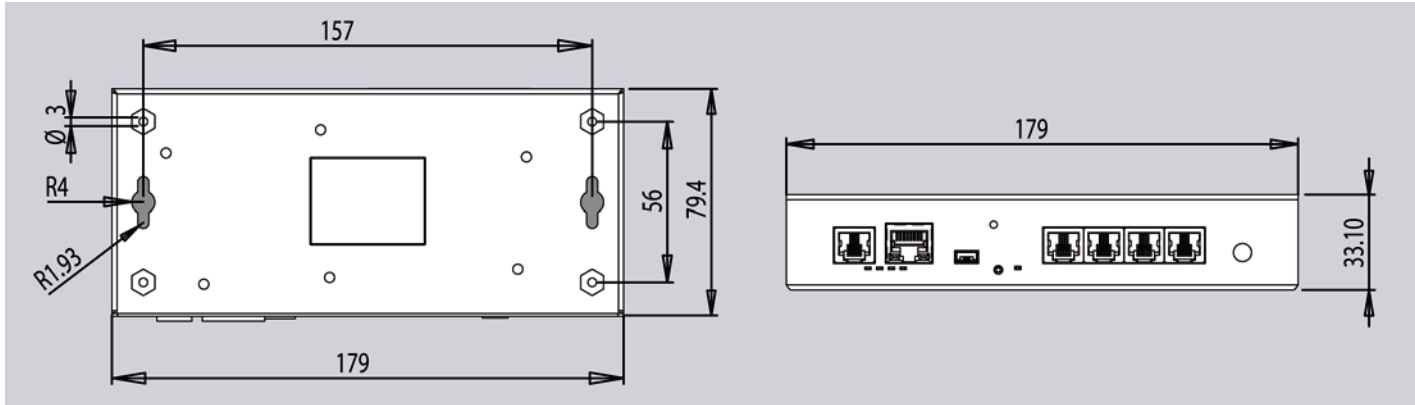

Dimensions (T.10.335 + T.10.102)

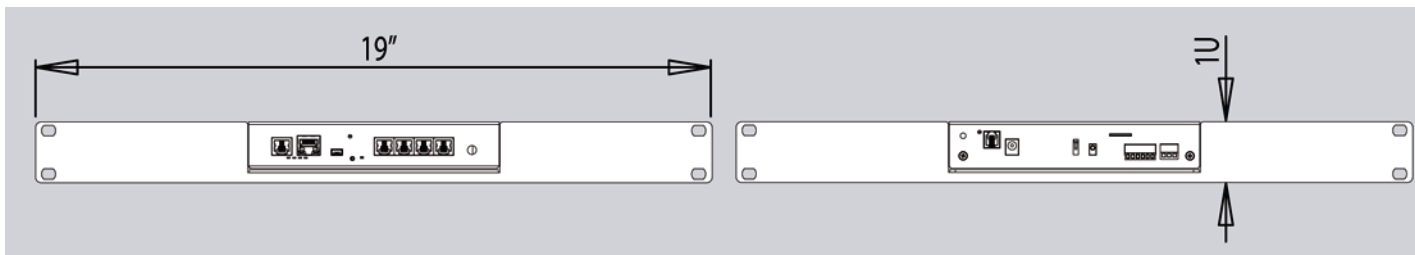

Mounting Options (T.10.335 + T.10.102)

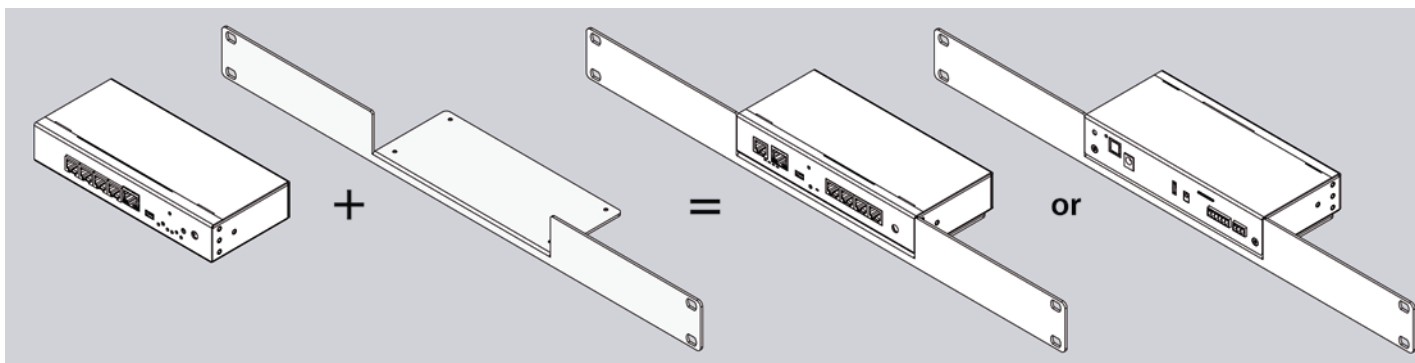

**Specifications are subject to change without notice based on technical recommendations and related product enhancements*

Order Options (Ordered Separately)

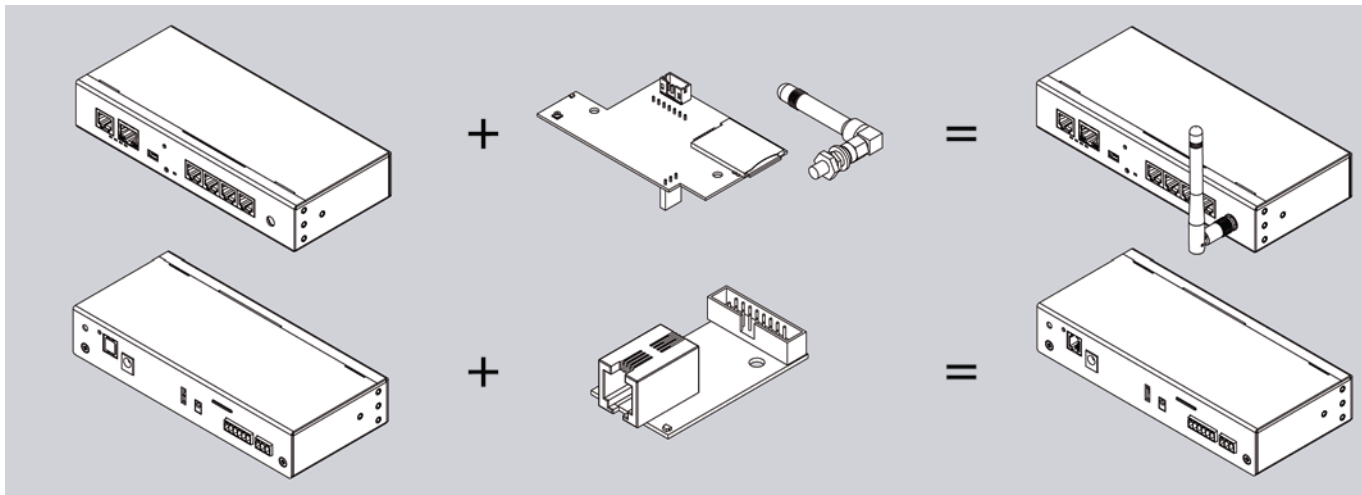

Monitoring System

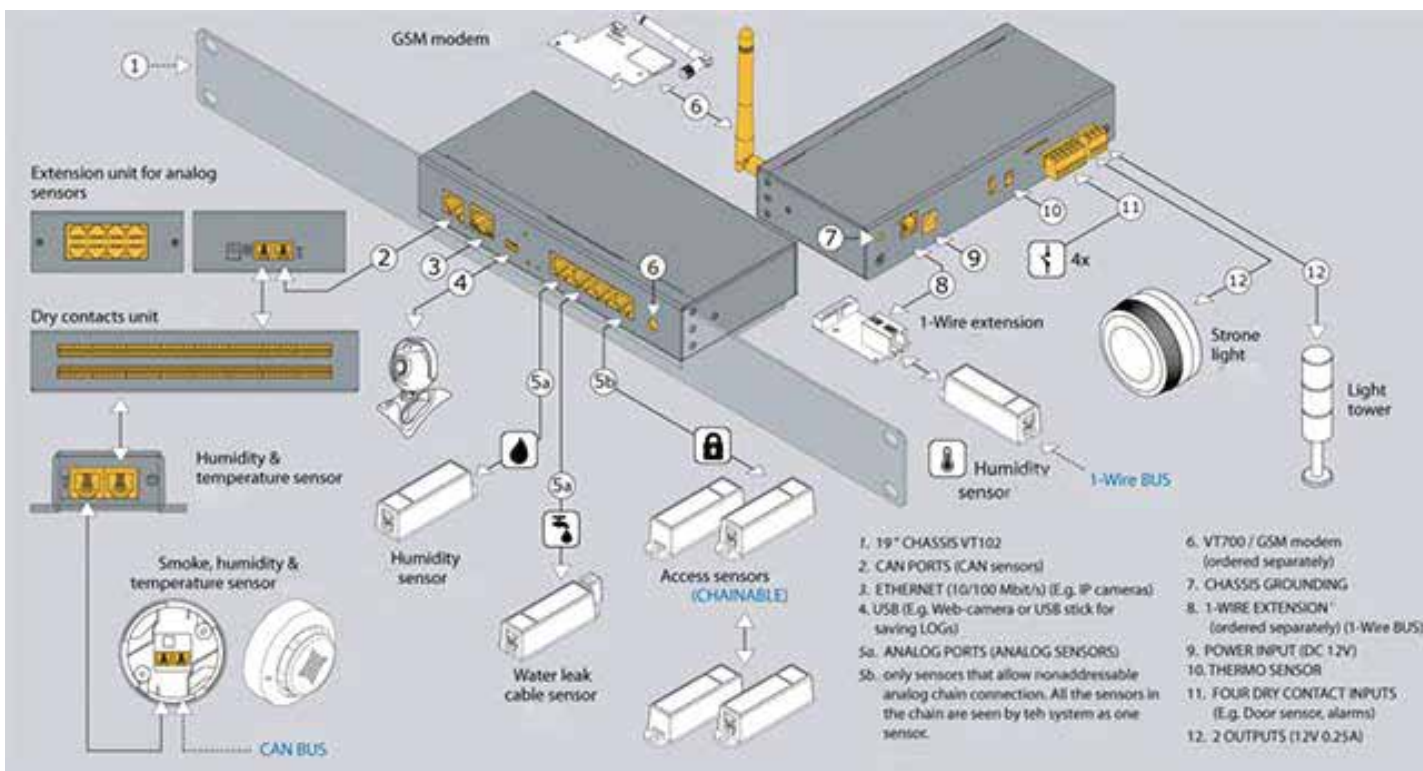

*Specifications are subject to change without notice based on technical recommendations and related product enhancements